

# Short process summary

Dr. Ákos Fürcht

11.03.2022



# Desalter

- **Aim:** removal of inorganic salt impurities
- **Feedstock:** raw crude oil + make-up water
- **Process parameters:**  $\sim 140^{\circ}\text{C}$ , 10 barg
- **Heat balance:** neutral
- **Additive:** demulsifier
- **Products:** desalted crude oil, salty waste water

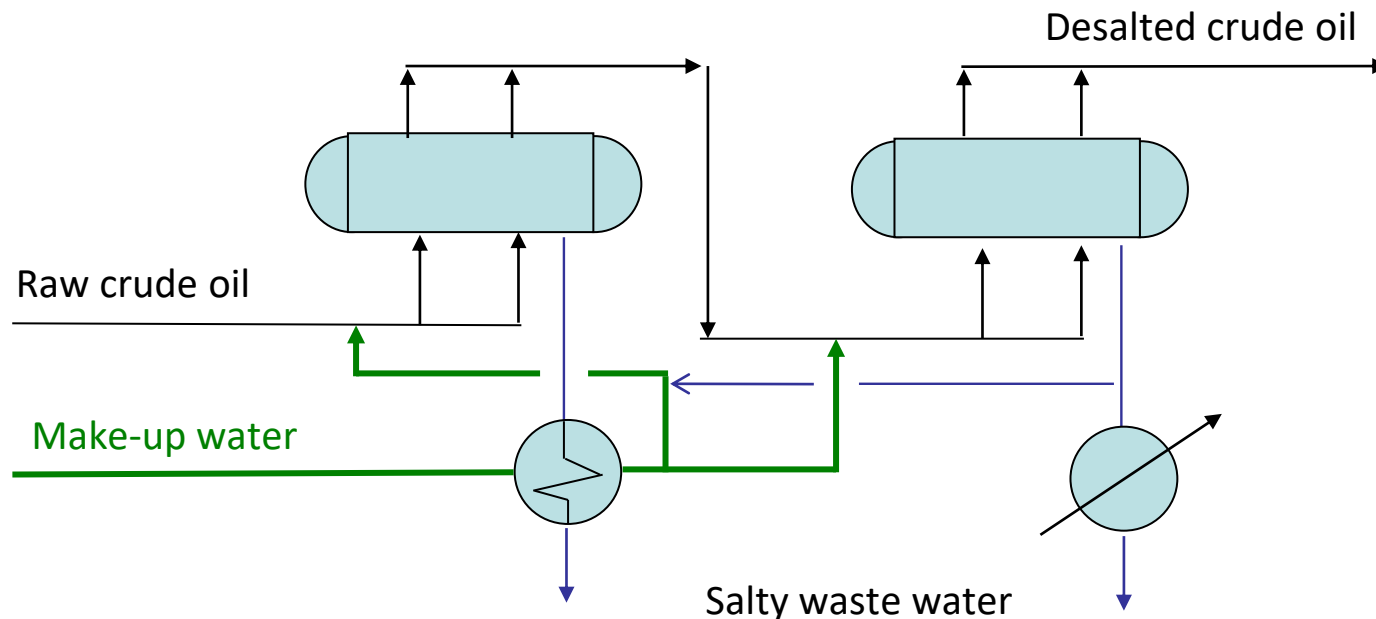

# Primary distillation (Atm & Vacuum)

- **Aim:** crude oil separation to main fractions
- **Feedstock:** desalted crude oil
- **Process parameters:** Atmospheric: ~1 bar, 320°C, Vacuum: 40 mbar, 410 °C
- **Heat balance:** neutral (no chemical reaction)
- **Additive:** corrosion inhibitor, filmer
- **Products:** fuel gas, LPG, light naphtha (LN), heavy naphtha (HN), petroleum, atmospheric gasoil, (atmospheric residue), vacuum gasoil, vacuum distillate, vacuum residue

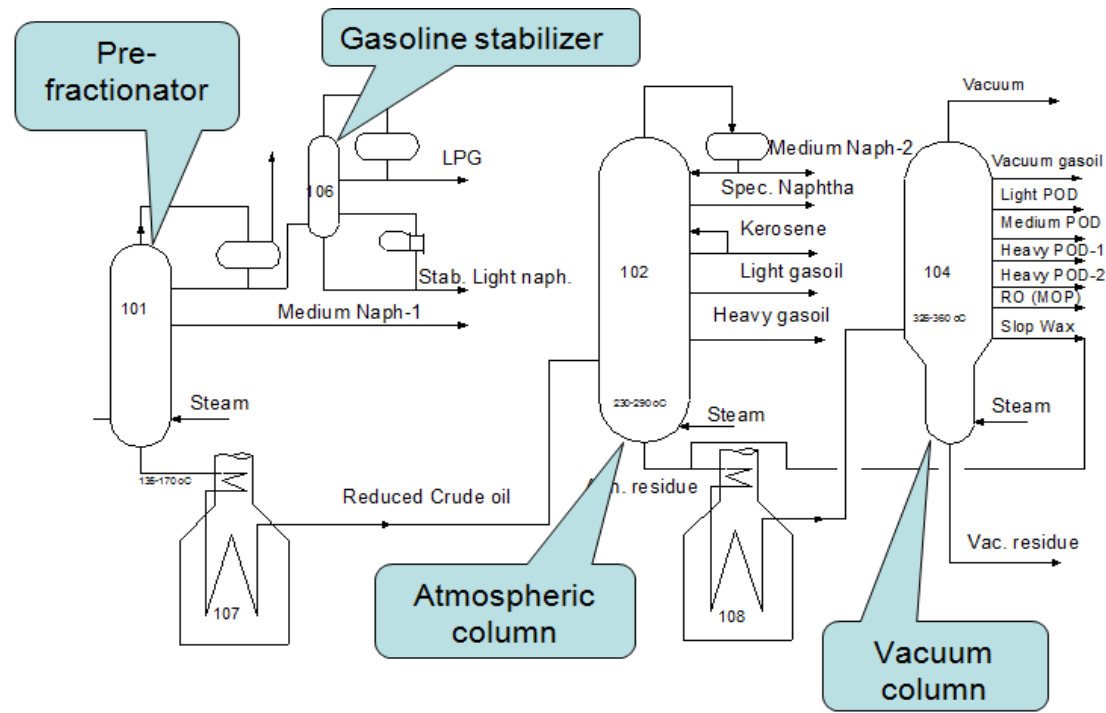

# LPG desulphurisation

- **Aim:** Impurities removal from LPG:  $H_2O$ ,  $H_2S$ ,  $CH_3SH$ ,  $COS$ ,  $CO_2$
- **Feedstock:** LPG from distillation origin, purified fuel gas
- **Process parameters:**  
Adsorption:  $\sim 20$  bar,  $25^\circ C$   
Regeneration:  $\sim 2$  bar,  $300^\circ C$
- **Heat balance:** neutral
- **Adsorbent:** 5A or 13X zeolit molecular sieve
- **Products:** desulphurised LPG, sour fuel gas

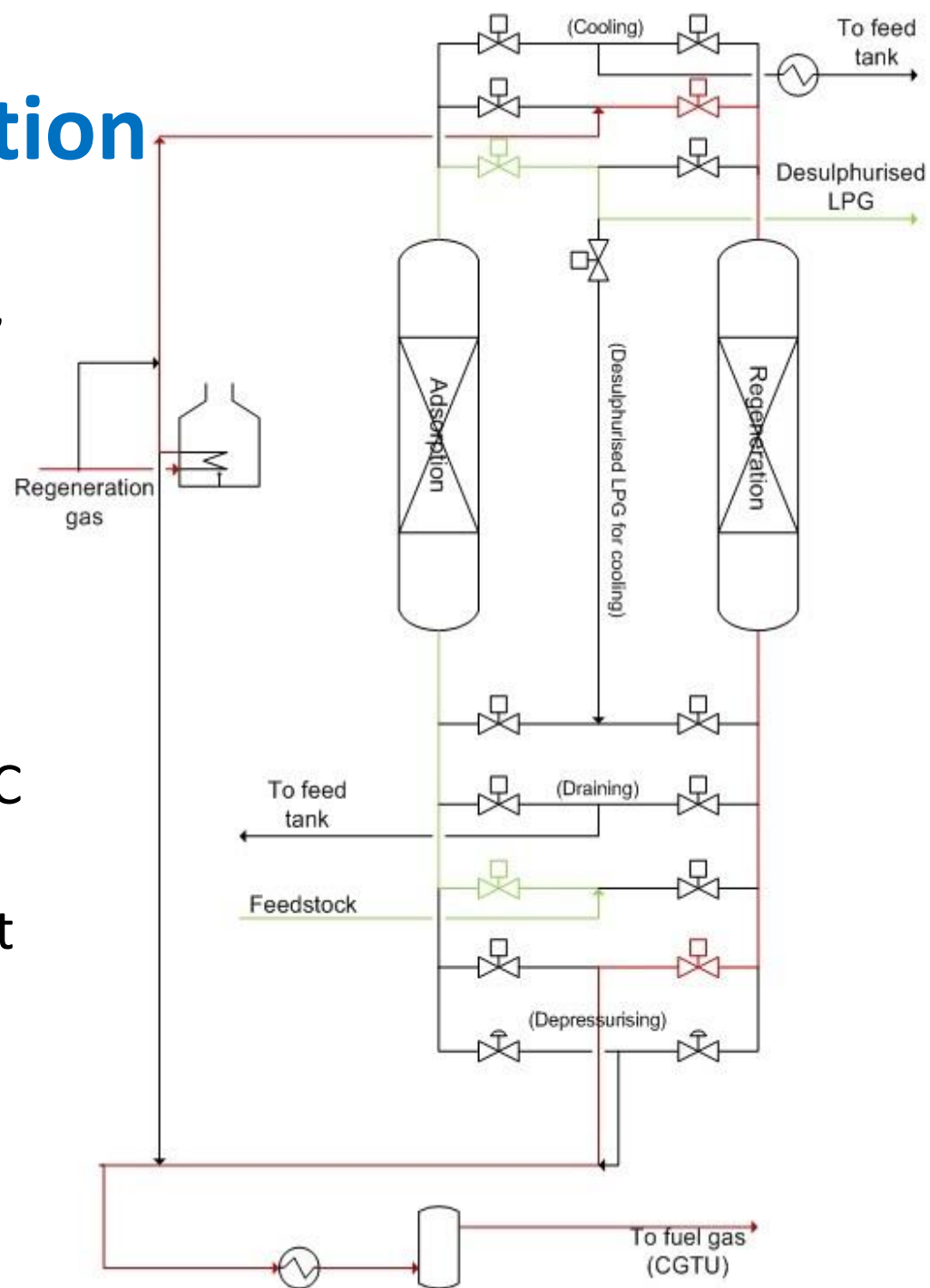

# Hydrotreating

- **Aim:** desulphurisation of gasoline/.../vacuum distillate fractions
- **Feedstock:** LN, HN, petroleum, gasoil, vacuum distillate and hydrogen
- **Process parameters:** 30-80 bar, 350-420 °C
- **Heat balance:** exothermic
- **Catalyst:** NiMo, CoMo, NiW
- **Products:** desulphurised LN, HN, petroleum, gasoil, vacuum distillate

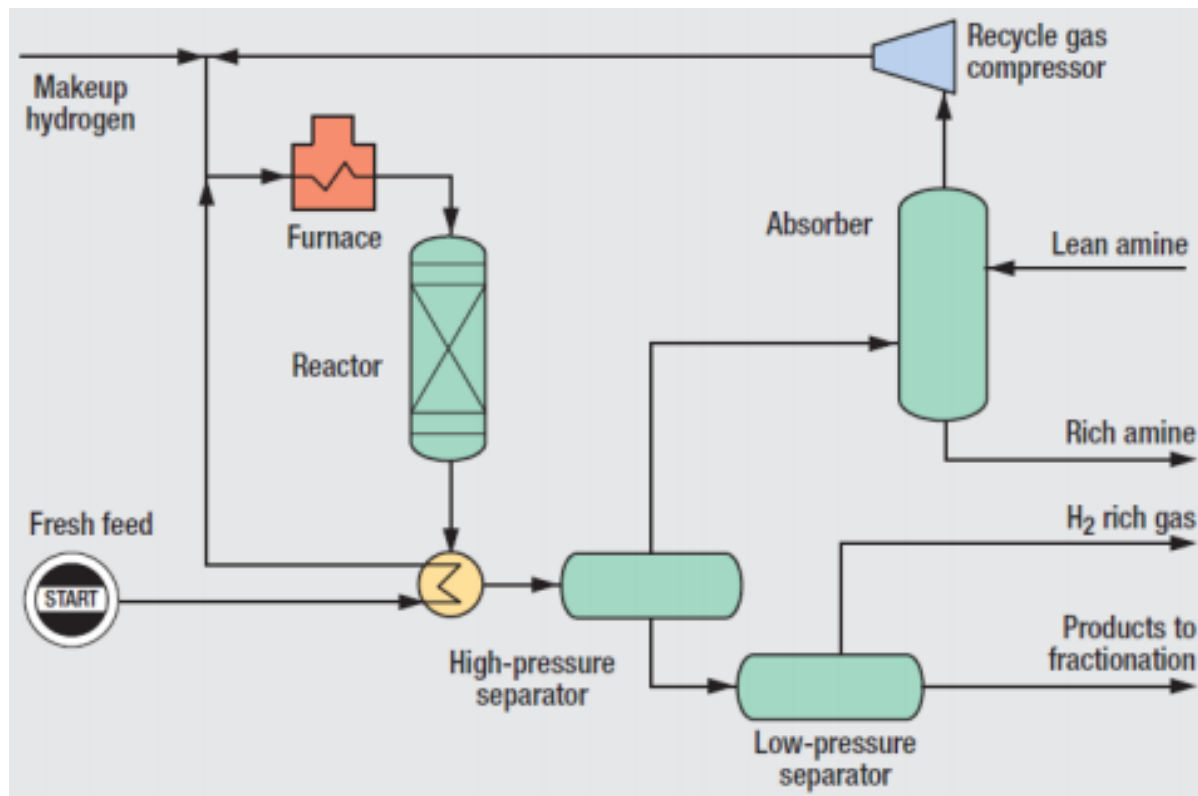

# LN isomersation

- **Aim:**  $nC_{5-6}$  transformation to  $iC_{5-6}$
- **Feedstock:** light naphtha
- **Process parameters:** 150-250°C, 20-30 bar
- **Heat balance:** exothermic
- **Catalyst:** Pt/ $Al_2O_3$
- **Products:**  $iC_5$ ,  $iC_6$

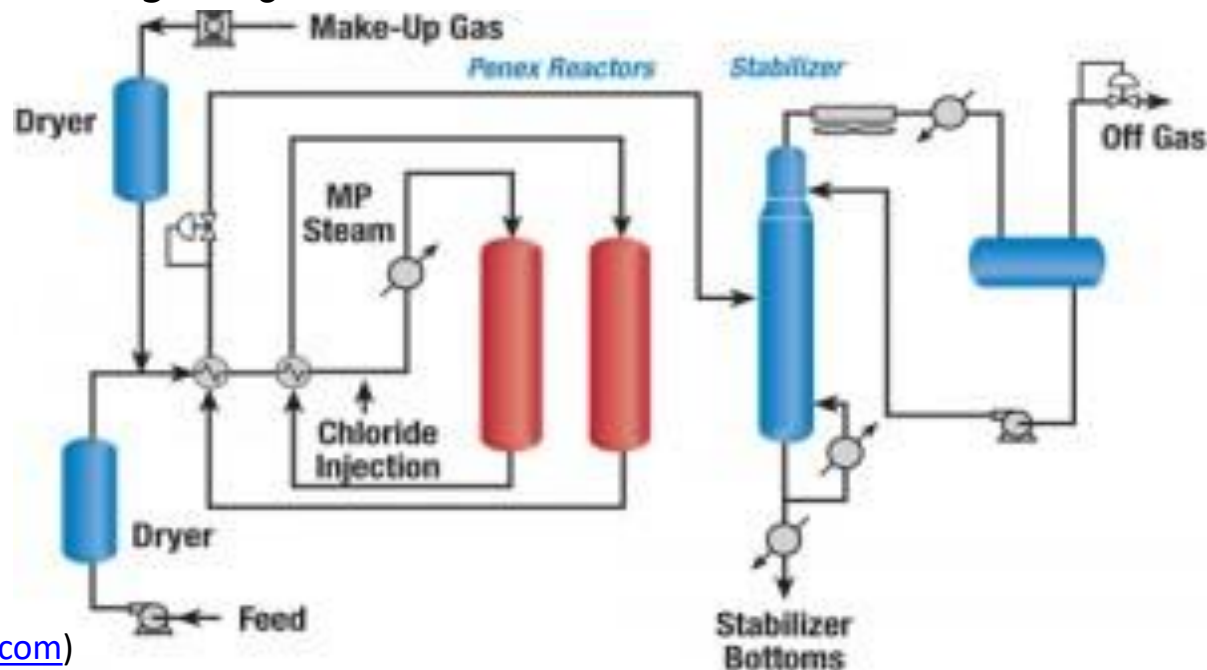

# CCR reforming

- **Aim:** Production of high octane gasoline blending component
- **Feedstock:** heavy naphtha
- **Process parameters:** ~500°C, 8 bar
- **Heat balance:** endothermic
- **Catalyst:** Pt-Re/Al<sub>2</sub>O<sub>3</sub>
- **Products:** reformate, hydrogen, benzene rich fraction

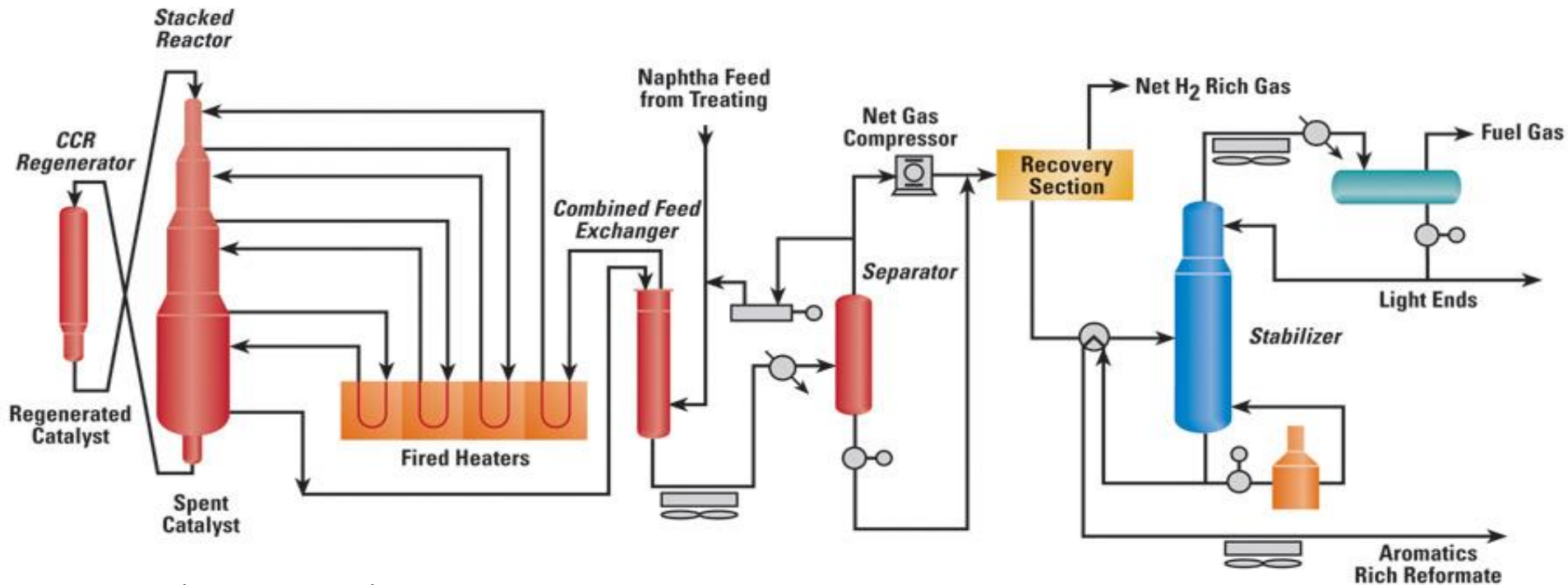

# Aromatic extraction

- **Aim:** production of individual aromatics (BTX)
- **Feedstock:** reformate, benzene rich fraction, pyrolysis C<sub>6-7</sub> fraction
- **Process parameters:** 8 bar, 130°C
- **Heat balance:** neutral
- **Solvent:** selective to aromatic molecules
- **Products:** benzene, toluene, xylenes

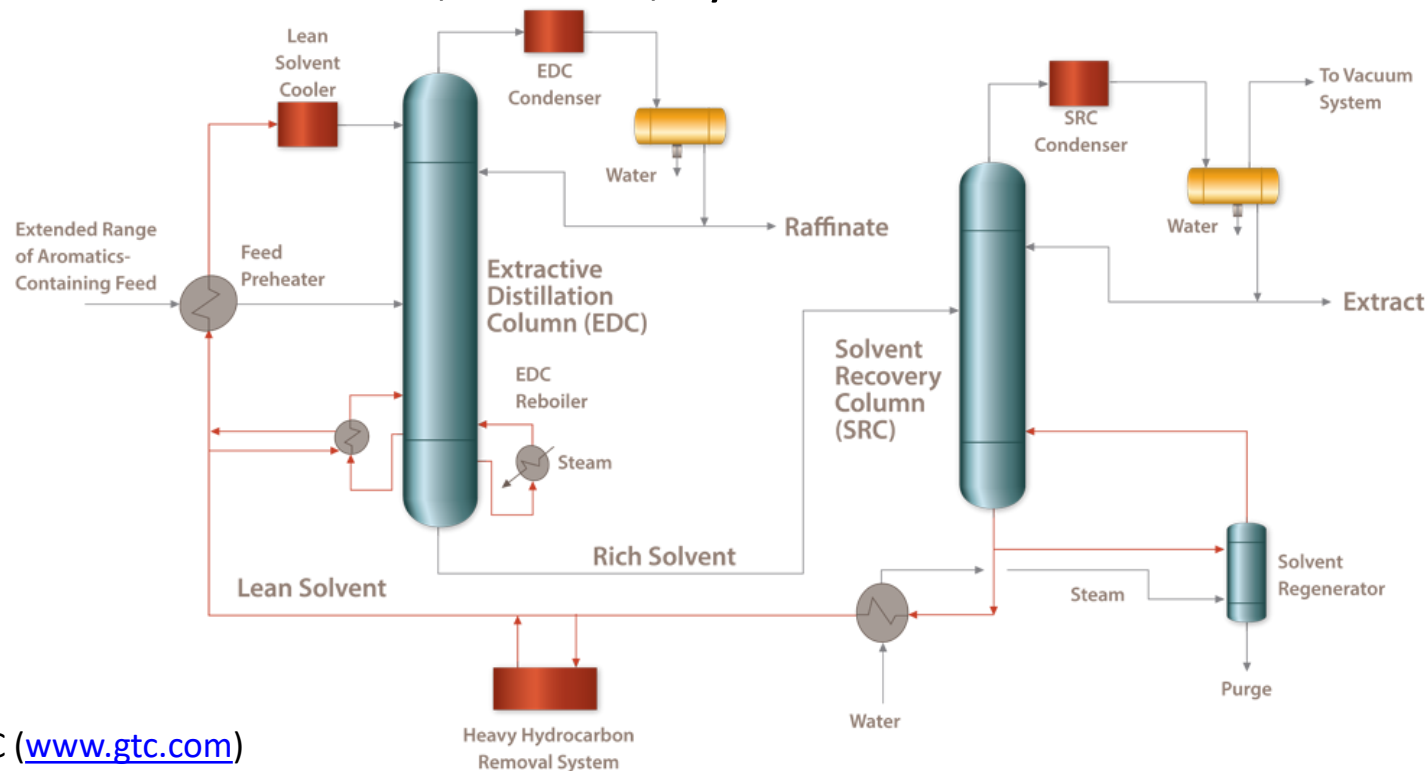



# Fluid catalytic cracking (FCC)

- **Aim:** valuable white products production via catalytic cracking
- **Feedstock:** (desulphurised) vacuum distillate
- **Process parameters:**  
540°C, 2-3 bar,  
 $t_{\text{contact}} = 1-2 \text{ s}$
- **Heat balance:** endothermic
- **Catalyst:** zeolite in  $\text{Al}_2\text{O}_3$  matrix
- **Products:** gasoline (~50%), olefinic LPG (~20%), gasoil, residue (MCB)

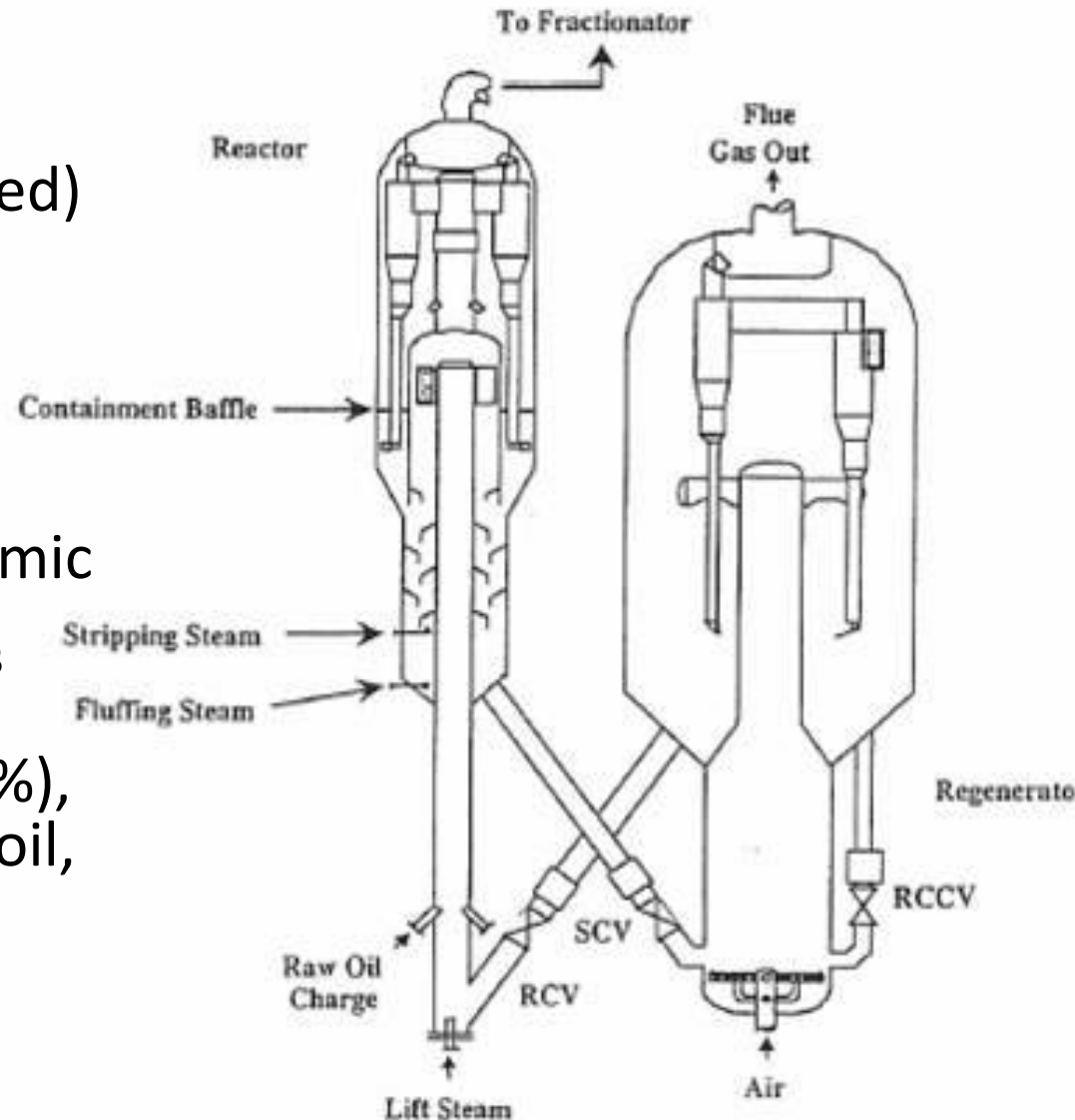

# Etherification

- **Aim:** production of high octane (bio) oxygenate
- **Feedstock:** olefinic C<sub>4</sub> fraction (isobutylene), (m)ethanol
- **Process parameters:** 50°C, 20 bar
- **Heat balance:** highly exothermic
- **Catalyst:** highly acidic ion exchange resin
- **Products:** MTBE/ETBE, C<sub>4</sub> raffinate (incl. other C<sub>4</sub> olefins)

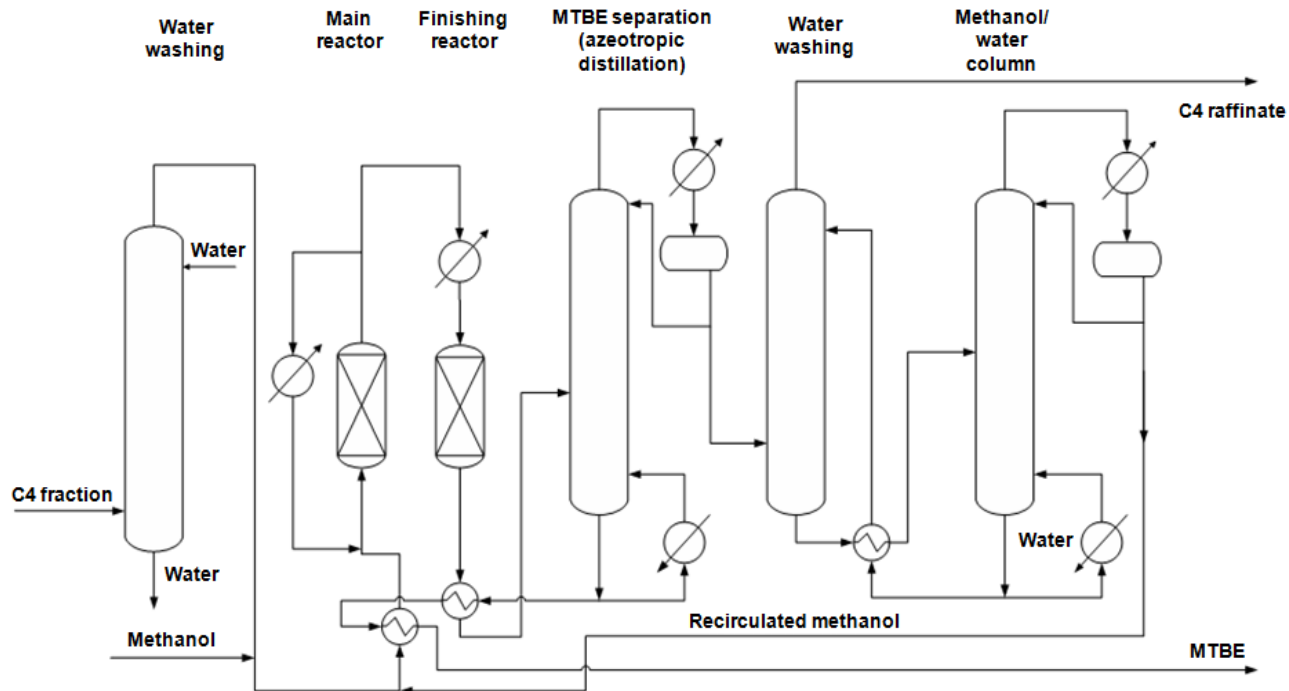

# (HF) Alkylation

- **Aim:** production of aromatic free gasoline blending component
- **Feedstock:** olefinic C<sub>4</sub> fraction, olefinic C<sub>3</sub> fraction and i-butane
- **Process parameters:** 30°C, 2-5 bar
- **Heat balance:** exothermic
- **Catalyst:** HF acid (or H<sub>2</sub>SO<sub>4</sub> in case of Sulphuric acid alkylation)
- **Products:** alkylate, n-butane, propane

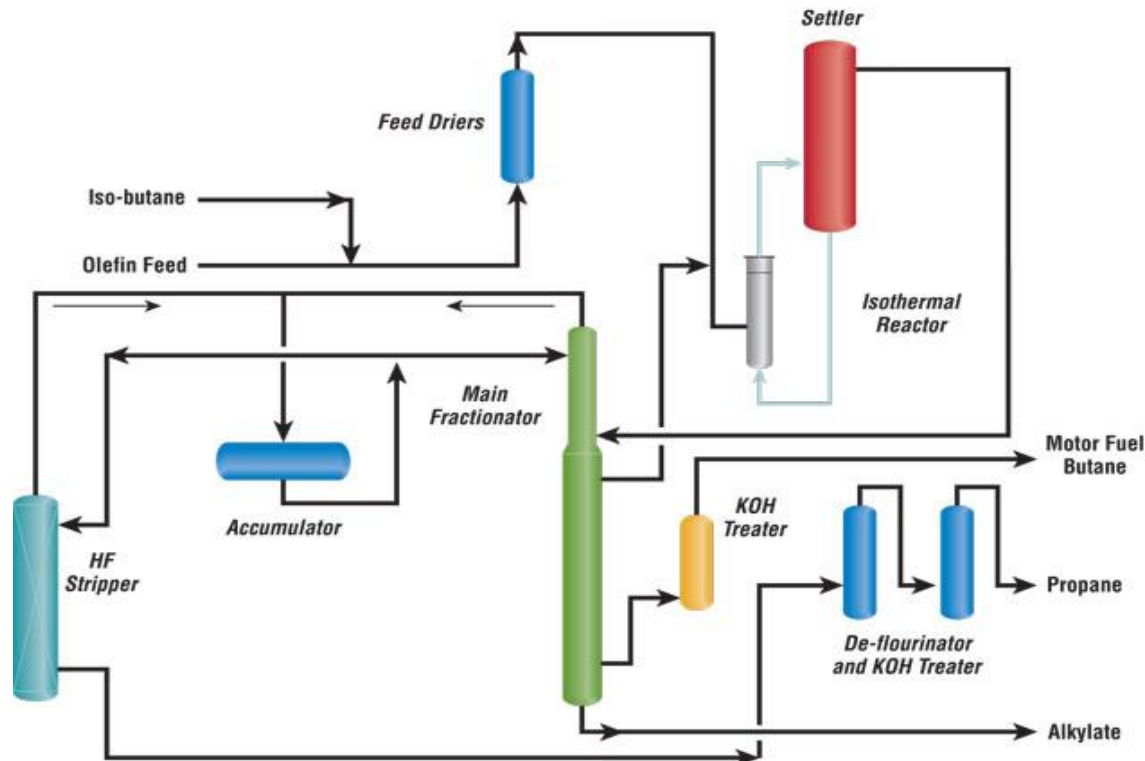

# Hydrocracking

- **Aim:** valuable white products production via hydrocracking
- **Feedstock:** (desulphurised) vacuum distillate and hydrogen
- **Process parameters:** 100-180 bar, 350-420 °C
- **Heat balance:** exothermic
- **Catalyst:** NiW, NiMo /amorphous/zeolite
- **Products:** gasoil, gasoline, LPG

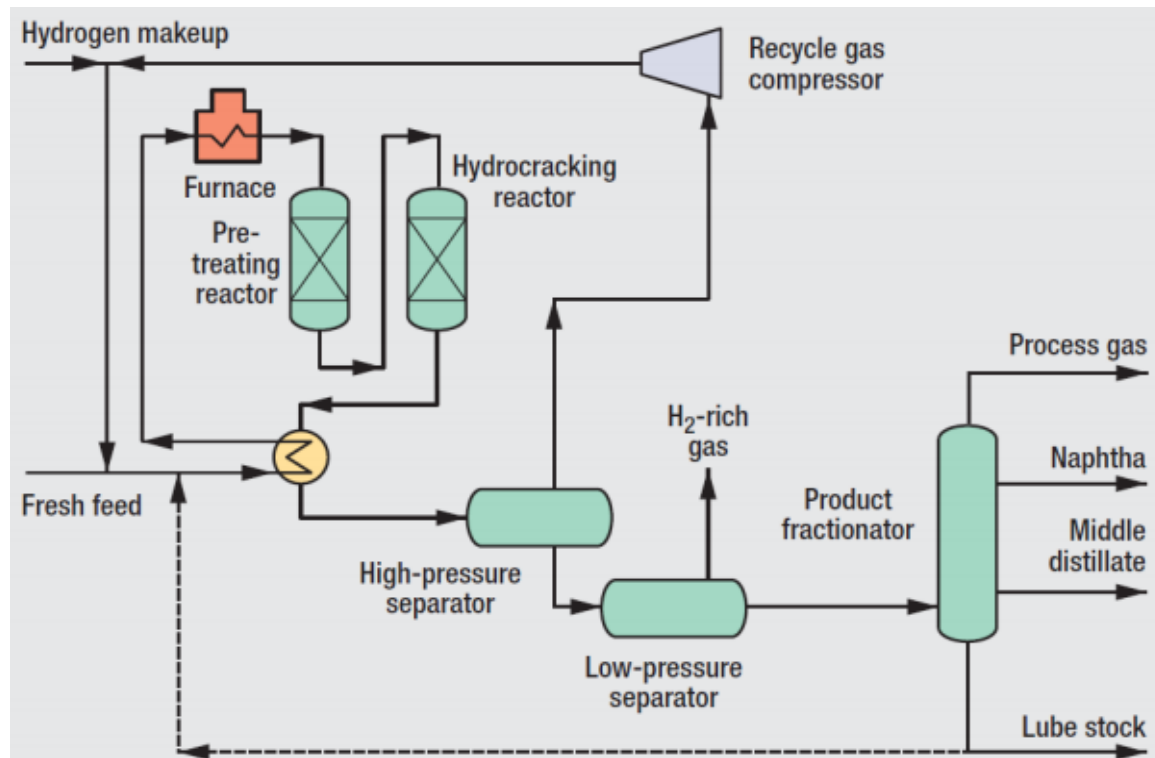

# Delayed coking

- **Aim:** valuable white products production via thermal cracking
- **Feedstock:** vacuum residue
- **Process parameters:** 3-5 bar, 500 °C
- **Heat balance:** endothermic
- **Catalyst:** -
- **Products (olefinic/sulphuric):** LPG, gasoline, gasoil, distillate, coke

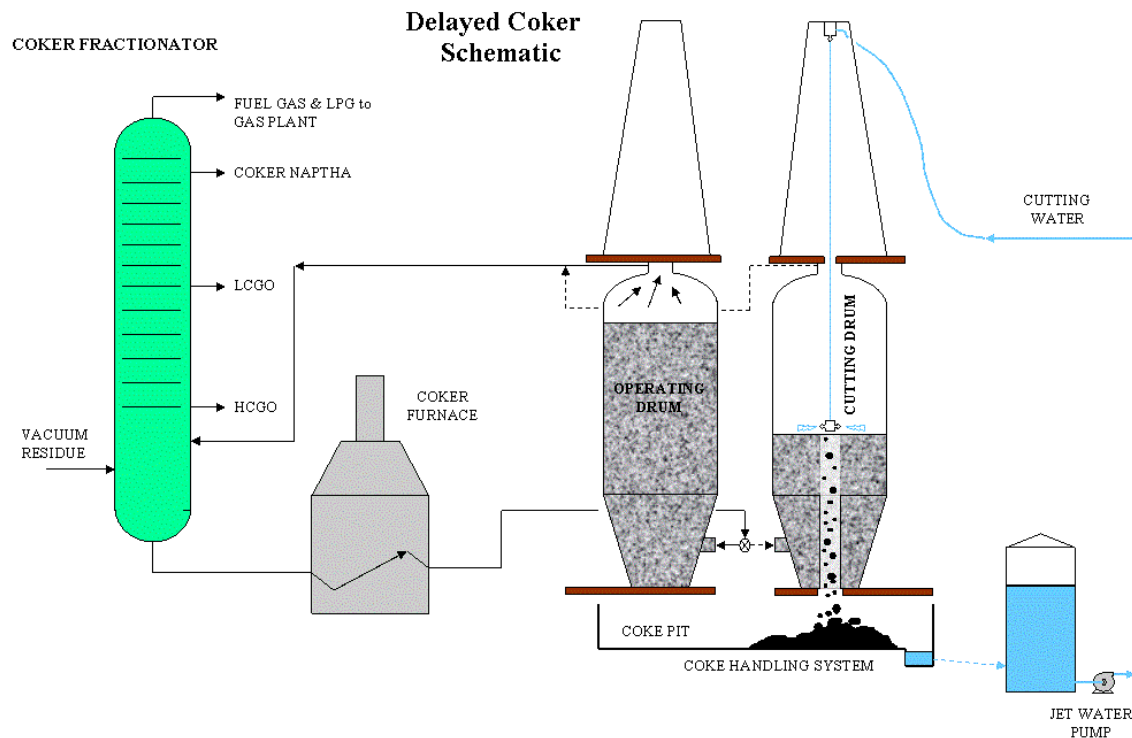

# Gasoline (diesel) blending

- **Aim:** continuous marketable final product (motoric fuel) formulation from actually available blending components (blending recipes may vary)
- **Feedstock:**
  - Blending components (straight run gasoline, FCC gasoline, MTBE, ETBE, alkylate gasoline, i-pentane, i-hexane, reformat gasoline, bio-ethanol)
  - Additives (quality and performance improvers)
- **Process solutions:** batch blending, in-line blending
- **Products:** motoric gasoline (RON95, premium, ...) motoric diesel (normal, premium, ...)

**The End**